

**Getting Started with Your
GPIB-ENET and the NI-488.2M™
Software for the Sun SPARCstation**

October 1995 Edition

Part Number 320528B-01

**© Copyright 1992, 1995 National Instruments Corporation.
All Rights Reserved.**

National Instruments Corporate Headquarters

6504 Bridge Point Parkway

Austin, TX 78730-5039

(512) 794-0100

Technical support fax: (800) 328-2203

(512) 794-5678

Branch Offices:

Australia 03 9 879 9422, Austria 0662 45 79 90 0, Belgium 02 757 00 20,

Canada (Ontario) 519 622 9310, Canada (Québec) 514 694 8521,

Denmark 45 76 26 00, Finland 90 527 2321, France 1 48 14 24 24,

Germany 089 741 31 30, Hong Kong 2645 3186, Italy 02 48301892,

Japan 03 5472 2970, Korea 02 596 7456, Mexico 95 800 010 0793,

Netherlands 03480 433466, Norway 32 84 84 00, Singapore 2265886,

Spain 91 640 0085, Sweden 08 730 49 70, Switzerland 056 200 51 51,

Taiwan 02 377 1200, U.K. 01635 523545

FCC/DOC Radio Frequency Interference Compliance

This equipment generates and uses radio frequency energy and, if not installed and used in strict accordance with the instructions in this manual, may cause interference to radio and television reception. This equipment has been tested and found to comply with the following two regulatory agencies:

Federal Communications Commission

This device complies with Part 15 of the Federal Communications Commission (FCC) Rules for a Class A digital device. Operation is subject to the following two conditions:

1. This device may not cause harmful interference in commercial environments.
2. This device must accept any interference received, including interference that may cause undesired operation.

Canadian Department of Communications

This device complies with the limits for radio noise emissions from digital apparatus set out in the Radio Interference Regulations of the Canadian Department of Communications (DOC).

Le présent appareil numérique n'émet pas de bruits radioélectriques dépassant les limites applicables aux appareils numériques de classe A prescrites dans le règlement sur le brouillage radioélectrique édicté par le ministère des communications du Canada.

Instructions to Users

These regulations are designed to provide reasonable protection against harmful interference from the equipment to radio reception in commercial areas. Operation of this equipment in a residential area is likely to cause harmful interference, in which case the user will be required to correct the interference at his own expense.

There is no guarantee that interference will not occur in a particular installation. However, the chances of interference are much less if the equipment is installed and used according to this instruction manual.

If the equipment does cause interference to radio or television reception, which can be determined by turning the equipment on and off, one or more of the following suggestions may reduce or eliminate the problem.

- Operate the equipment and the receiver on different branches of your AC electrical system.
- Move the equipment away from the receiver with which it is interfering.
- Reorient or relocate the receiver's antenna.
- Be sure that the equipment is plugged into a grounded outlet and that the grounding has not been defeated with a cheater plug.

Notice to user: Changes or modifications not expressly approved by National Instruments could void the user's authority to operate the equipment under the FCC Rules.

If necessary, consult National Instruments or an experienced radio/television technician for additional suggestions. The following booklet prepared by the FCC may also be helpful: *How to Identify and Resolve Radio-TV Interference Problems*. This booklet is available from the U.S. Government Printing Office, Washington, DC 20402, Stock Number 004-000-00345-4.

Limited Warranty

The GPIB-ENET is warranted against defects in materials and workmanship for a period of two years from the date of shipment, as evidenced by receipts or other documentation. National Instruments will, at its option, repair or replace equipment that proves to be defective during the warranty period. This warranty includes parts and labor.

The media on which you receive National Instruments software are warranted not to fail to execute programming instructions, due to defects in materials and workmanship, for a period of 90 days from date of shipment, as evidenced by receipts or other documentation. National Instruments will, at its option, repair or replace software media that do not execute programming instructions if National Instruments receives notice of such defects during the warranty period. National Instruments does not warrant that the operation of the software shall be uninterrupted or error free.

A Return Material Authorization (RMA) number must be obtained from the factory and clearly marked on the outside of the package before any equipment will be accepted for warranty work. National Instruments will pay the shipping costs of returning to the owner parts which are covered by warranty.

National Instruments believes that the information in this manual is accurate. The document has been carefully reviewed for technical accuracy. In the event that technical or typographical errors exist, National Instruments reserves the right to make changes to subsequent editions of this document without prior notice to holders of this edition. The reader should consult National Instruments if errors are suspected. In no event shall National Instruments be liable for any damages arising out of or related to this document or the information contained in it.

EXCEPT AS SPECIFIED HEREIN, NATIONAL INSTRUMENTS MAKES NO WARRANTIES, EXPRESS OR IMPLIED, AND SPECIFICALLY DISCLAIMS ANY WARRANTY OF MERCHANTABILITY OR FITNESS FOR A PARTICULAR PURPOSE. CUSTOMER'S RIGHT TO RECOVER DAMAGES CAUSED BY FAULT OR NEGLIGENCE ON THE PART OF NATIONAL INSTRUMENTS SHALL BE LIMITED TO THE AMOUNT THEREFORE PAID BY THE CUSTOMER. NATIONAL INSTRUMENTS WILL NOT BE LIABLE FOR DAMAGES RESULTING FROM LOSS OF DATA, PROFITS, USE OF PRODUCTS, OR INCIDENTAL OR CONSEQUENTIAL DAMAGES, EVEN IF ADVISED OF THE POSSIBILITY THEREOF. This limitation of the liability of National Instruments will apply regardless of the form of action, whether in contract or tort, including negligence. Any action against National Instruments must be brought within one year after the cause of action accrues. National Instruments shall not be liable for any delay in performance due to causes beyond its reasonable control. The warranty provided herein does not cover damages, defects, malfunctions, or service failures caused by owner's failure to follow the National Instruments installation, operation, or maintenance instructions; owner's modification of the product; owner's abuse, misuse, or negligent acts; and power failure or surges, fire, flood, accident, actions of third parties, or other events outside reasonable control.

Copyright

Under the copyright laws, this publication may not be reproduced or transmitted in any form, electronic or mechanical, including photocopying, recording, storing in an information retrieval system, or translating, in whole or in part, without the prior written consent of National Instruments Corporation.

Trademarks

NI-488.2M™ is a trademark of National Instruments Corporation.

Product and company names listed are trademarks or trade names of their respective companies.

WARNING REGARDING MEDICAL AND CLINICAL USE OF NATIONAL INSTRUMENTS PRODUCTS

National Instruments products are not designed with components and testing intended to ensure a level of reliability suitable for use in treatment and diagnosis of humans. Applications of National Instruments products involving medical or clinical treatment can create a potential for accidental injury caused by product failure, or by errors on the part of the user or application designer. Any use or application of National Instruments products for or involving medical or clinical treatment must be performed by properly trained and qualified medical personnel, and all traditional medical safeguards, equipment, and procedures that are appropriate in the particular situation to prevent serious injury or death should always continue to be used when National Instruments products are being used. National Instruments products are NOT intended to be a substitute for any form of established process, procedure, or equipment used to monitor or safeguard human health and safety in medical or clinical treatment.

Contents

About This Manual	xi
Organization of This Manual	xi
Conventions Used in This Manual.....	xii
Related Documentation	xiii
Customer Communication	xiii

Chapter 1

Introduction	1-1
How to Use This Manual	1-1
What You Need to Get Started	1-2
Optional Multiple-Computer Software License.....	1-2
Hardware Description	1-3
The GPIB-ENET Side Panel	1-5
Software Description	1-5

Chapter 2

Configuring and Installing the Hardware	2-1
Configure the GPIB-ENET Operating Characteristics	2-1
Configure the Slide Switch	2-1
Configure the DIP Switch	2-2
Connect the Cables	2-2

Chapter 3

Installing and Configuring the Software	3-1
Configure the Network	3-1
Configure the Host	3-2
Step 1. Enable the rarpd daemon.....	3-2
Step 2. Modify the /etc/ethers System File	3-3
Step 3. Modify the /etc/hosts System File	3-3
Step 4. Reboot the System	3-4
Install the Software	3-4
Step 1. Preparation	3-4
Step 2. Installation	3-5
Set Up a Working Directory	3-5
Automatically Installing the Software	3-5
Manually Installing the Software	3-5
Step 3. Switch on Your GPIB-ENET	3-6
Step 4. Update the GPIB-ENET Firmware	3-6
Step 5. Configure Subnet Information	3-7
Step 6. Configure the Software	3-7
Increase the Allowed Number of Boxes or Devices (Optional).....	3-7

Chapter 4	
Verification and Troubleshooting	4-1
Verify the Hardware Installation	4-1
Troubleshooting Hardware Problems	4-1
Verify the Software Installation	4-2
Troubleshooting Software Problems	4-2
Common Questions	4-3
Chapter 5	
Using Your NI-488.2M Software	5-1
Introduction to the ibic Utility	5-1
General Programming Considerations	5-1
Appendix A	
Hardware Specifications	A-1
Appendix B	
GPIB-ENET 8-Bit DIP Switch	B-1
Appendix C	
GPIB-ENET Configuration Utilities	C-1
IPassign Utility.....	C-1
Update Utility.....	C-2
IPsetup Utility	C-3
Appendix D	
READY LED Signaling	D-1
READY LED Overview	D-1
Step 1. Count the Long Flashes	D-1
Step 2. Count the Short Flashes	D-2
Step 3. Record Your Status Code Number	D-2
Appendix E	
Customer Communication	E-1
Glossary	G-1

Figures

Figure 1-1.	GPIB-ENET Top Panel and LEDs	1-3
Figure 1-2.	GPIB-ENET Side Panel	1-5
Figure 2-1.	GPIB-ENET Back Panel Switches	2-1
Figure 2-2.	Default Switch Setting for Ethernet Port Configuration	2-1
Figure 2-3.	Switch Setting for AUI Ethernet Port Configuration	2-2
Figure 3-1.	GPIB-ENET Bottom Panel Identification Label	3-1
Figure B-1.	GPIB-ENET Back Panel Switches	B-1

Tables

Table 1-1.	LED Descriptions	1-4
Table A-1.	Electrical Characteristics	A-1
Table A-2.	Environmental Characteristics	A-1
Table A-3.	Physical Characteristics	A-1
Table B-1.	DIP Switch Settings for Modes of Operation	B-1
Table D-1.	Sample READY LED Signals and the Corresponding Status Code Numbers	D-2

About This Manual

This manual contains instructions for installing and configuring the National Instruments GPIB-ENET and NI-488.2M multitasking software driver for use with the Sun SPARCstation running under SunOS 4.1.2 or higher operating system. This manual is meant to be used with the *NI-488.2M Software Reference Manual*.

The material in this assumes that you have knowledge of the Sun SPARCstation running under SunOS 4.1.2 or higher and have super-user privilege. This manual also assumes that you are familiar with Ethernet and Internet networks.

Organization of This Manual

This manual is organized as follows:

- Chapter 1, *Introduction*, explains how to use this manual, lists what you need to get started, and briefly describes the GPIB-ENET and the NI-488.2M software.
- Chapter 2, *Configuring and Installing the Hardware*, gives instructions for configuring and installing the GPIB-ENET.
- Chapter 3, *Installing and Configuring the Software*, contains instructions for configuring the network and host and for installing and configuring the NI-488.2M software.
- Chapter 4, *Verification and Troubleshooting*, describes how to verify the hardware and software installation and troubleshoot problems.
- Chapter 5, *Using Your NI-488.2M Software*, describes the *ibic* utility and lists some programming considerations.
- Appendix A, *Hardware Specifications*, lists the electrical, environmental, and physical characteristics of the GPIB-ENET and the recommended operating conditions.
- Appendix B, *GPIB-ENET 8-Bit DIP Switch*, describes how each of the DIP switches on the back panel affects the operation of the GPIB-ENET.
- Appendix C, *GPIB-ENET Configuration Utilities*, contains information on the *IPassign*, *Update*, and *IPsetup* utilities for the GPIB-ENET.
- Appendix D, *READY LED Signaling*, describes how to interpret the **READY** LED error codes.

About This Manual

- Appendix E, *Customer Communication*, contains forms you can use to request help from National Instruments or to comment on our products and manuals.
- The *Glossary* contains an alphabetical list and a description of the terms, including abbreviations, acronyms, metric prefixes, mnemonics, and symbols, that this manual uses.

Conventions Used in This Manual

The following conventions are used in this manual:

bold	Bold text denotes the name of a light emitting diode (LED).
<i>italic</i>	Italic text denotes emphasis, a cross reference, or an introduction to a key concept.
<i>bold italic</i>	Bold italic text denotes a note, caution, or warning.
<i>italic monospace</i>	Italic text in this font denotes that you must supply the appropriate words or values in the place of these items.
monospace	Text in this font denotes text or characters that are to be literally input from the keyboard. It also denotes sections of code, syntax examples, proper names of paths, directories, programs, functions, utilities, and filenames.
<>	Angle brackets enclose the name of a key on the keyboard—for example, <Delete>.
-	A hyphen between two or more key names enclosed in angle brackets denotes that you should simultaneously press the named keys—for example, <Stop-A>.
IEEE 488 and IEEE 488.2	IEEE 488 and IEEE 488.2 refer to the ANSI/IEEE Standard 488.1-1987 and the ANSI/IEEE Standard 488.2-1992, respectively, which define the GPIB.

Abbreviations, acronyms, metric prefixes, mnemonics, symbols and terms are listed in the *Glossary*.

Related Documentation

The following documents contain information that you may find helpful as you read this manual:

- ANSI/IEEE Standard 488.1-1987, *IEEE Standard Digital Interface for Programmable Instrumentation*
- ANSI/IEEE Standard 488.2-1992, *IEEE Standard Codes, Formats, Protocols, and Common Commands*
- ANSI/IEEE Standard 802.3-1988, *Information Processing Systems, Local Area Networks, Part 3*
- *Solaris 1.0.1 Release Overview* (for SunOS 4.1.2), Sun Microsystems, Inc., Mountain View, California 94043
- *SPARCstation 1 Installation Guide*, Sun Microsystems, Inc., Mountain View, California 94043
- *SPARCstation 2 Installation Guide*, Sun Microsystems, Inc., Mountain View, California 94043

Customer Communication

National Instruments wants to receive your comments on our products and manuals. We are interested in the applications you develop with our products, and we want to help if you have problems with them. To make it easy for you to contact us, this manual contains comment and configuration forms for you to complete. These forms are in Appendix E, *Customer Communication*, at the end of this manual.

Chapter 1 Introduction

This chapter explains how to use this manual, lists what you need to get started, and briefly describes the GPIB-ENET and the NI-488.2M software.

How to Use This Manual

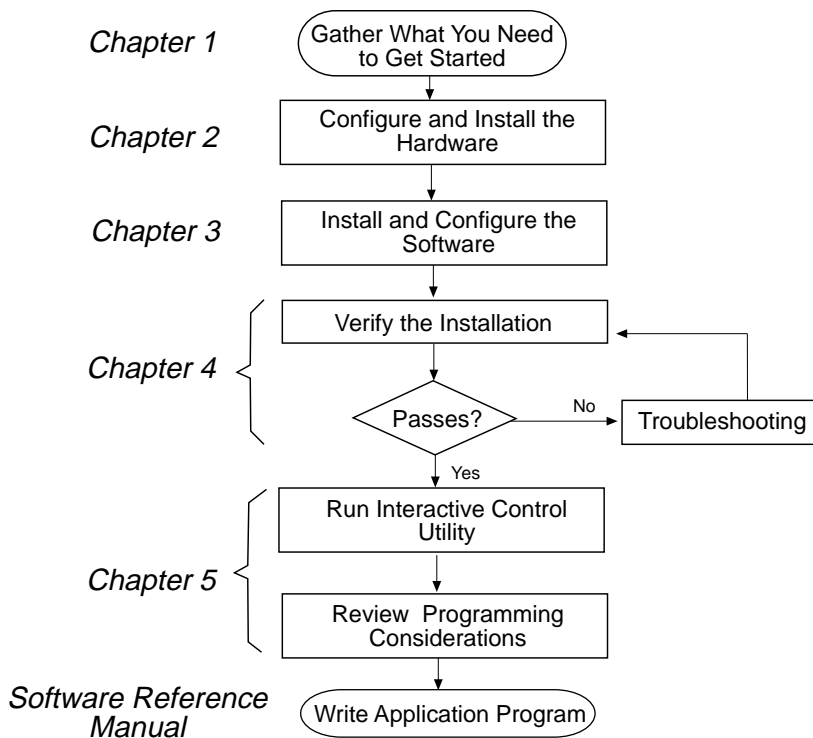

What You Need to Get Started

- ❑ One of the following boxes, which is included in your kit:
 - GPIB-ENET - 10Base-T Version (100-120 VAC)
 - GPIB-ENET - 10Base-T Version (220-240 VAC)
 - GPIB-ENET - Coax Version (100-120 VAC)
 - GPIB-ENET - Coax Version (220-240 VAC)

 - ❑ One of the following power cords, which is included in your kit:
 - U.S.A. standard power cord
 - Switzerland power cord
 - Australian power cord
 - Universal European power cord
 - North American power cord
 - U.K. power cord

 - ❑ Both of these software media, which are included in your kit:
 - 3.5 in. *NI-488.2M Distribution Disk for GPIB-ENET Sun SPARCstation*
 - SunOS 4.1.2 Driver and C Interface*

 - ❑ SunOS 4.1.2 or higher installed on your computer.

 - ❑ Ethernet cables, which you can purchase from National Instruments:
 - Twisted Pair (10Base-T) cables (1 m, 5 m, or 10 m)
 - Coax (10Base-2) cables (1 m, 5 m, or 10 m)
 - AUI (10Base-5) cables (1 m, 5 m, or 10 m)

 - ❑ Shielded GPIB Cables*, which you can purchase from National Instruments
 - Type X1 single-shielded cables (1 m, 2 m, or 4 m)
 - Type X2 double-shielded cables (1 m, 2 m, or 4 m)
- * To meet FCC emission limits for this device, you must use a shielded (Type X1 or X2) GPIB cable. Operating this equipment with a non-shielded cable may cause interference to radio and television reception.

Optional Multiple-Computer Software License

A multiple-computer software license is available so that one or more hosts on a single physical network may access one or more GPIB-ENET boxes. Contact National Instruments for more information regarding the license.

Hardware Description

The GPIB-ENET transparently handles data transfers between an Ethernet-based TCP/IP host and the GPIB. With the GPIB-ENET, multiple hosts can share a set of GPIB instruments or a single host can control several GPIB systems.

The GPIB-ENET converts a computer equipped with an NI-488.2M driver and an Ethernet port into a GPIB Talker/Listener/Controller. The GPIB-ENET is powered by an internal 100-120 VAC or 220-240 VAC supply.

The GPIB-ENET has all the firmware and logic required to implement the physical and electrical characteristics of all versions of the ANSI/IEEE 488 standard, including ANSI/IEEE Standard 488.2-1992, and ANSI/IEEE Standard 802.3. The GPIB-ENET interprets and executes commands that you send to it over an Ethernet link and performs all necessary Ethernet-to-GPIB protocol conversions. For detailed hardware specifications, refer to Appendix A, *Hardware Specifications*.

Figure 1-1 shows the top panel of the GPIB-ENET. Seven status Light Emitting Diodes (LEDs) are mounted on the GPIB-ENET top panel.

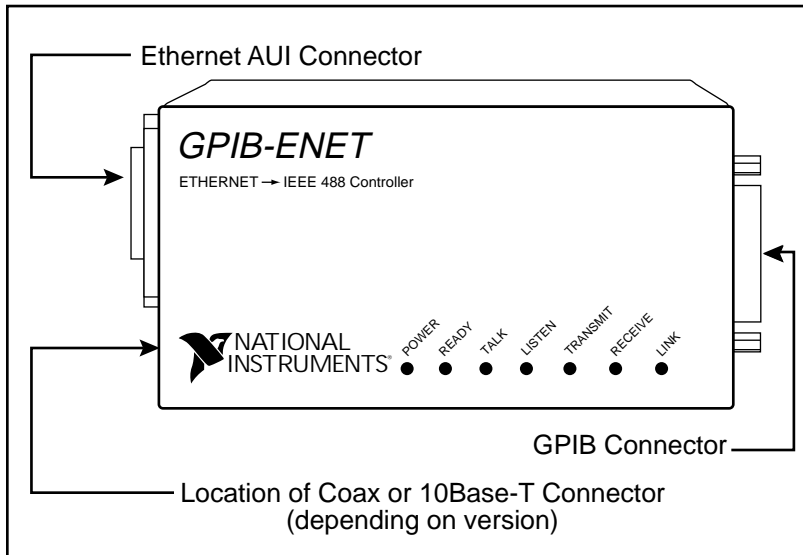

Figure 1-1. GPIB-ENET Top Panel and LEDs

The LEDs show the current status of the GPIB-ENET. Table 1-1 describes each LED.

Table 1-1. LED Descriptions

LED	Indication
POWER	Indicates that power has been supplied to the unit and the ON/OFF switch is in the ON position.
READY	Indicates the functional state of the GPIB-ENET. When the GPIB-ENET is powered on, this LED flashes and then becomes steady when the box is ready for operation. Continuous flashing indicates an error has occurred.
TALK	Indicates that the GPIB-ENET is configured as a GPIB Talker.
LISTEN	Indicates that the GPIB-ENET is configured as a GPIB Listener.
TRANSMIT	Indicates that the GPIB-ENET is transmitting onto the Ethernet network.
RECEIVE	Indicates that the GPIB-ENET is receiving Ethernet network traffic.
LINK	Indicates that the GPIB-ENET has detected a twisted pair (10Base-T) link. For GPIB-ENET coax and AUI options, this LED is not used and remains OFF.

The GPIB-ENET Side Panel

Figure 1-2 shows the side panels of the 10Base-T and coax versions of the GPIB-ENET.

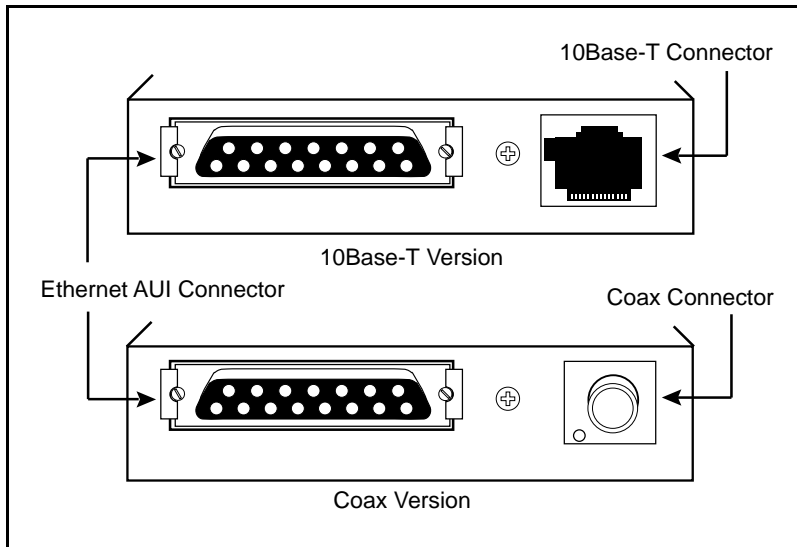

Figure 1-2. GPIB-ENET Side Panel

Software Description

The NI-488.2M software and GPIB hardware transform a Sun SPARCstation into a GPIB Talker/Listener/Controller that has complete communications and bus management capability. The NI-488.2M software includes the following components:

- NI-488.2M Language Interface Library
- Software diagnostic test
- Configuration utilities
- Interactive control program

For a list of the actual files included on the distribution media, refer to the *Install the Software* section of Chapter 3, *Installing and Configuring the Software*.

Chapter 2

Configuring and Installing the Hardware

This chapter gives instructions for configuring and installing the GPIB-ENET.

Configure the GPIB-ENET Operating Characteristics

The GPIB-ENET has a two-position slide switch that you use to configure the network interface connector of the box. The GPIB-ENET also has an 8-bit DIP switch used to configure the operating characteristics. The switches are located on the back panel of the GPIB-ENET, as shown in Figure 2-1.

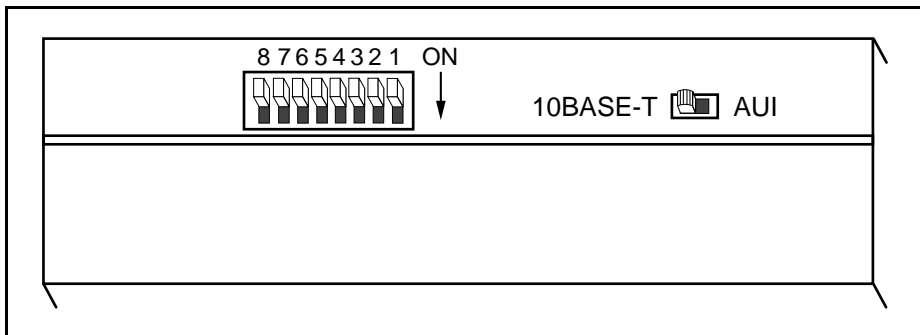

Figure 2-1. GPIB-ENET Back Panel Switches

Configure the Slide Switch

Your GPIB-ENET has two network interface connectors: a 15-pin AUI connector and either a 10Base-T Ethernet connector or a coax Ethernet connector. Use the slide switch to select which of the two connectors the GPIB-ENET uses. The default switch setting is either 10Base-T or coax. Figure 2-2 depicts the default setting for the different types of GPIB-ENET boxes.

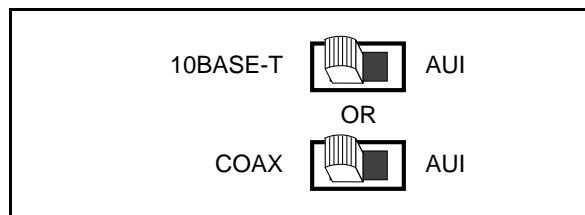

Figure 2-2. Default Switch Setting for Ethernet Port Configuration

If you want to use the AUI connector, change the switch setting to match the appropriate setting in Figure 2-3.

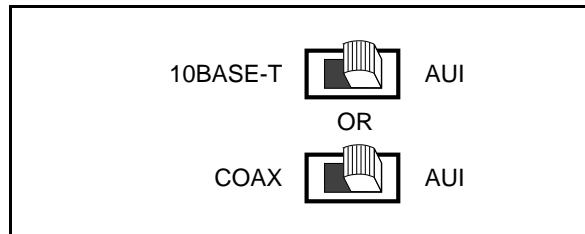

Figure 2-3. Switch Setting for AUI Ethernet Port Configuration

Configure the DIP Switch

The 8-bit DIP switch selects the operating mode of the GPIB-ENET. The GPIB-ENET is shipped to you with the DIP switch set for normal operation mode. In normal operation mode, all the switches are in the OFF position. Most users want to use the GPIB-ENET in normal operation mode. Do not change the DIP switch settings unless you run a GPIB-ENET utility that prompts you to change them. For information about using the 8-bit DIP switch, refer to Appendix B, *GPIB-ENET 8-Bit DIP Switch*.

Connect the Cables

If you do not have both a GPIB cable and Ethernet cable, contact National Instruments for ordering information.

The GPIB-ENET is shipped from the factory with either a 100-120 VAC or 220-240 VAC power supply. Before you configure your GPIB-ENET, verify that the voltage rating listed on the bottom of the box matches the voltage that is supplied in your area.

Warning: *Operating the GPIB-ENET at any voltage other than the one specified could damage the unit.*

1. Connect one end of the Ethernet cable to the GPIB-ENET and securely fasten it. Connect the other end of the Ethernet cable to your Ethernet network. Be sure to follow all IEEE 802.3 cabling restrictions.

2. Connect one end of the GPIB cable to the GPIB-ENET and tighten the thumb screws on the connector. Connect the other end of the GPIB cable to your GPIB system. Be sure to follow all IEEE 488.1 cabling restrictions and use only shielded GPIB cables.
3. Plug the power cord into an AC outlet of the correct voltage, but do *not* power on the GPIB-ENET at this time.

Chapter 3

Installing and Configuring the Software

This chapter contains instructions for configuring the network and host and for installing and configuring the NI-488.2M software.

Configure the Network

The following steps explain how to set up the GPIB-ENET on your network:

The Internet Protocol (IP) address is the address that TCP/IP-based networks use to route information to the appropriate network and host. When you first install a GPIB-ENET in a network, or if the IP address for the GPIB-ENET changes, the GPIB-ENET IP address must be configured.

1. Note the Ethernet address from the bottom panel label of the GPIB-ENET.

The Ethernet address is not the same thing as the IP address. All devices on an Ethernet network are assigned a physical address, the Ethernet address, so that they can communicate with each other. The identification label on the bottom panel of the GPIB-ENET contains various information, including the Ethernet address. See Figure 3-1 for a picture of the GPIB-ENET identification label.

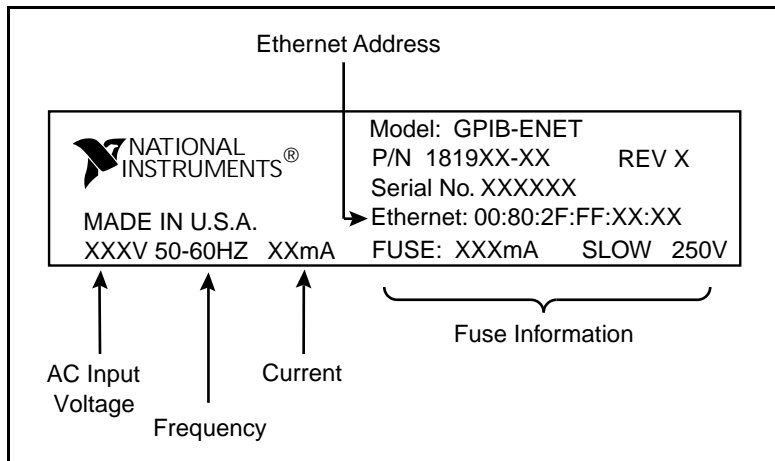

Figure 3-1. GPIB-ENET Bottom Panel Identification Label

2. Contact your network administrator to use the GPIB-ENET on your network.

Your network administrator assigns a unique, valid IP address to your GPIB-ENET. At this time, you or your system administrator should also assign a fully-qualified official hostname to the GPIB-ENET—for example, `gpib0.natinst.com`. Your network administrator can also tell you whether the GPIB-ENET should have its IP address configured automatically or manually. A Reverse Address Resolution Protocol (RARP) server on the network automatically configures the GPIB-ENET with an IP address when you power on the GPIB-ENET; once your network administrator has configured your network RARP server, you can use automatic configuration. If a RARP server is not available, you can configure the IP address manually using the `IPassign` utility. Once you configure the IP address, it is stored in the GPIB-ENET so that you do not need to reassign it every time you power on the box.

3. Make a note of the IP address configured for the GPIB-ENET hardware. You must use this IP address when you configure your host computer and the NI-488.2M software.

Configure the Host

Follow these steps to configure the GPIB-ENET node within SunOS.

1. Enable the `rarpd` daemon.
2. Modify the `/etc/ethers` system file.
3. Modify the `/etc/hosts` system file.

To complete these steps, you must log on the Sun SPARCstation with super-user privileges. These steps are described in more detail in the following sections.

Step 1. Enable the `rarpd` daemon

The GPIB-ENET uses the RARP Ethernet protocol to obtain the IP address. For the SPARCstation to respond to the RARP Ethernet protocol, you must run the `rarpd` daemon. To enable the `rarpd` daemon, create a directory in the root level path with the name `tftpboot`. If this directory already exists, skip to Step 2. If `tftpboot` does not exist, enter the following command to create the directory.

```
mkdir /tftpboot
```

When you boot your computer, the system file `rc.local` checks to see whether the `tftpboot` directory exists, and if so, automatically enables the `rarpd` daemon.

Note: *It is not necessary to reboot your computer at this time.*

Step 2. Modify the `/etc/ethers` System File

The `rarpd` daemon uses the `/etc/ethers` file to associate an Ethernet address with an official host name. If the `/etc/ethers` file does not exist, you must create it at this time. You must edit the `/etc/ethers` file and add an entry for the GPIB-ENET. Create the entry in the following format:

```
Ethernet-address           official-host-name
```

Ethernet-address is the address shown on the label of the GPIB-ENET box in the format "`x:x:x:x:x:x`" where `x` is a hex number between `00` and `ff`. For more information on the Ethernet address, refer to the *Configure the Network* section earlier in this chapter. *official-host-name* is the name you or your network administrator chose for the GPIB-ENET and should be a fully qualified hostname, which includes your domain-name extension.

The following is an example `/etc/ethers` entry:

```
20:22:24:26:28:30           gpib0.natinst.com
```

For more information about `/etc/ethers`, refer to the man pages for `ethers` (5) or contact your network administrator.

Step 3. Modify the `/etc/hosts` System File

You must edit the `/etc/hosts` file and add an entry for the GPIB-ENET. Create the entry in the following format:

```
Internet-address           official-host-name aliases
```

Internet-address is the IP address you assign to the GPIB-ENET, *official-host-name* is the name you or your network administrator chose for the GPIB-ENET and should be a fully qualified hostname, which includes your domain-name extension, and *aliases* is any other name(s) you want to associate with the box. You should add at least one alias to the entry because the software configuration utility, `ibconf`, uses this alias to locate the GPIB-ENET. The default configuration expects the alias `gpib0` for the first GPIB-ENET, `gpib1` for the second GPIB-ENET, `gpib2` for the third GPIB-ENET, and so on.

The following is an example `/etc/hosts` entry.

```
130.164.1.212 gpib0.natinst.com  gpib0
```

where `gpib0.natinst.com` is the official-host-name and `gpib0` is the default alias that `ibconf` uses. If you use an alias other than the default, you must change the alias in `ibconf` to match the alias you are using.

For more information about `/etc/hosts`, refer to the man pages for `hosts (5)` or contact your network administrator.

Step 4. Reboot the System

Reboot your system for the changes to take effect.

Install the Software

Step 1. Preparation

Before installing the NI-488.2M software, consider the following.

- You must have super-user privilege.
- The *NI-488.2M Distribution Disk for GPIB-ENET Sun SPARCstation Sun OS 4.1.2 Driver and C Interface* is in BAR format.

The NI-488.2M distribution media contains the following files and utilities.

- `cib.o` is the C language interface library.
- `ugplib.h` is the include file for user programs.
- `gpibr.c` is the NI-488.2M configuration file.
- `ibtsta` is the installation test file.
- `ibic` is the interactive control utility.
- `ibconf` is the software configuration utility.
- `Update` is a utility that updates the GPIB-ENET firmware.
- `IPassign` is a utility that assigns an IP address to the GPIB-ENET.
- `GPIBENET.bin` is the GPIB-ENET firmware.
- `IPsetup` is a utility to configure subnet information.

Step 2. Installation

Perform the following steps to install the NI-488.2M software. You may install the software automatically or manually.

Set Up a Working Directory

1. Log on as super-user (`root`).
2. Create a working directory (for example, `/usr/gpib`) and change to that directory.
3. Copy the files from the NI-488.2M distribution media to this directory by using the following command:

```
bar xvf /dev/rfd0c
```

Automatically Installing the Software

To install the NI-488.2M software automatically, run `instgpib` in your working directory by entering the following command:

```
./instgpib
```

Manually Installing the Software

To install the NI-488.2M software manually, you must install the utility files and the C library as described in the following steps.

1. Copy the file `ugpib.h` to `/usr/include/sys`.
2. Copy the file `gpibrc` to `/etc`.
3. Copy files `ibic`, `ibconf`, and `ibtsta` to a directory in the command search path (for example, `/usr/bin`) by entering the following commands:

```
cp ibic /usr/bin
cp ibconf /usr/bin
cp ibtsta /usr/bin
```

4. To install the C library, convert the file `cib.o` into a C library. This procedure is necessary if you are compiling your application with the `-lgpib` option. Refer to the section titled *General Programming Considerations* in Chapter 5, *Using Your NI-488.2M Software* for more information. To create a C language library, enter the following commands:

```
ar rv /lib/libgpib.a cib.o
ranlib /lib/libgpib.a
```

Alternatively, you can add `cib.o` to an existing library or include `cib.o` during the link phase of each compile operation.

Step 3. Switch on Your GPIB-ENET

Warning: *Operating the GPIB-ENET at any voltage other than the one specified could damage the unit.*

The GPIB-ENET is shipped from the factory with either a 100-120 VAC or 220-240 VAC power supply. Before operating your GPIB-ENET, verify that the voltage rating listed on the bottom of the box matches the voltage that is supplied in your area.

To assign the IP address manually, refer to Appendix C, *GPIB-ENET Configuration Utilities*, and run the `IPAssign` utility.

For automatic IP address assignment using a RARP server, power on the GPIB-ENET. The **POWER** LED comes on immediately. The **READY** LED flashes while the GPIB-ENET completes its power-on self tests and the IP address is assigned.

The power-on self tests take about 10 seconds to complete, then the box obtains its IP address. The time required for the IP address assignment is highly dependent on your network and the configuration of your GPIB-ENET. If the **READY** LED does not become steady after one minute, refer to the *Troubleshooting Hardware Problems* section of Chapter 4, *Verification and Troubleshooting*.

Once the **READY** LED remains steady, the unit is ready to operate and you can configure the software.

Step 4. Update the GPIB-ENET Firmware

To insure that you have the latest version of the GPIB-ENET firmware, update your firmware using the image file included with your most recent NI-488.2M distribution disk. See the *Update Utility* section of Appendix C, *GPIB-ENET Configuration Utilities* for instructions on updating your firmware.

Step 5. Configure Subnet Information

Before the GPIB-ENET is fully functional, you should configure it with proper subnet information. Your GPIB-ENET may work properly even if you skip this step, but National Instruments recommends that you configure information about the subnet. This information includes the broadcast IP address and netmask to use on the subnet and up to four router IP addresses. Refer to Appendix C, *GPIB-ENET Configuration Utilities*, and run the `IPsetup` utility.

Step 6. Configure the Software

The GPIB software configuration utility, `ibconf`, is an interactive utility that you can use to examine or modify the configuration of the driver.

To run `ibconf`, enter the following command:

```
ibconf
```

`ibconf` displays a list of all the GPIB interfaces and device names. You can use the online help if you have any questions.

Increase the Allowed Number of Boxes or Devices (Optional)

The GPIB-ENET NI-488.2M software supports eight GPIB-ENET boxes and 44 devices by default. If you want to use more GPIB-ENET boxes or devices, you can use `ibconf` to create a new `/etc/gpibrbc` file that will allow the NI-488.2M software to access up to 128 boards and 128 devices. Perform the following steps to create a new `/etc/gpibrbc` to use more than eight GPIB-ENET boxes and 44 devices:

Note: *You must have super-user privileges to perform the following steps.*

1. Make a backup copy of the current `/etc/gpibrbc` in a separate directory and delete the current `/etc/gpibrbc` file.

2. Execute `ibconf` with the following options:

```
ibconf -b Nboards -d Ndevices
```

Where *Nboards* is the number of boards you want the GPIB-ENET to support (the minimum is 1, the maximum is 128, and the default is 8); and *Ndevices* is the number of devices you want the GPIB-ENET to support (the minimum is 44, the maximum is 128, and the default is 44).

3. Press <Y> when `ibconf` prompts you to create the new file.
4. Edit the `ibconf` file to suit your application.

Note: `ibconf` *will configure the first 44 devices; you can configure other devices (during run time only) using `ibfind()`, `ibconfig()` or `ibdev()`, `ibconfig()`.*

For more information about `ibconf`, refer to the *NI-488.2M Software Reference Manual*. After you have configured the software, you are ready to verify the installation. Continue to Chapter 4, *Verification and Troubleshooting*.

Chapter 4

Verification and Troubleshooting

This chapter describes how to verify the hardware and software installation and troubleshoot problems.

Verify the Hardware Installation

When you power on your GPIB-ENET, the **POWER** LED comes on immediately. The **READY** LED flashes while it completes its power-on self-tests. When the tests complete successfully and the IP address is assigned, the **READY** LED remains steady, indicating that the unit is ready to operate.

The power-on self-tests take about 10 seconds to complete. The time required for the IP address assignment is highly dependent on your network and the configuration of your GPIB-ENET. If the **POWER** LED does not come on immediately or the **READY** LED continues to flash for more than one minute, refer to the next section, *Troubleshooting Hardware Problems*. Otherwise, proceed to the *Verify the Software Installation* section, later in this chapter.

Troubleshooting Hardware Problems

Warning: *The GPIB-ENET contains circuitry that operates with hazardous voltages. Do not attempt to open and service the box. Refer servicing to qualified personnel.*

- Verify that all cables are securely connected to the GPIB-ENET.
- Verify that the GPIB-ENET is powered on. If the unit is powered on and plugged into an outlet of the proper voltage, yet you see no LED activity, check the condition of the fuse.

Warning: *For continued protection against fire, replace the fuse with only the same type and rating of fuse. See Appendix A, Hardware Specifications, for fuse specifications.*

- Verify that the Ethernet port configuration slide switch is set to the correct Ethernet port. Refer to the *Configure the Slide Switch* section of Chapter 2, *Configuring and Installing the Hardware*, for more information.

- Verify that the DIP switch settings are configured properly for your setup. Refer to the *Configure the DIP Switch* section of Chapter 2, *Configuring and Installing the Hardware*, and also to Appendix B, *GPIB-ENET 8-Bit DIP Switch*, for more information.
- Verify that your IP address is valid and that the network is set up to recognize the IP address properly.
- If you configured the IP address manually using the `IPassign` utility, verify that you have correctly followed the steps in Appendix C, *GPIB-ENET Configuration Utilities*.
- If the **READY** LED continues to flash for more than one minute, you have a problem with your setup. If the **READY** LED is flashing quickly, the GPIB-ENET is unable to obtain its IP address from the network. In this case, check with your network administrator to verify your IP address and make sure that you recorded the Ethernet address correctly. If the **READY** LED is blinking slowly, the GPIB-ENET has an internal error. In this case, refer to Appendix D, *READY LED Signaling*, to determine which error is being reported and contact National Instruments.

Verify the Software Installation

To test the software installation, and to verify that the software and hardware communicate properly, run the software diagnostic test `ibtsta` that came with your NI-488.2M software.

Follow these steps to run `ibtsta`:

1. Complete all hardware and software installation and configuration.
2. Disconnect any GPIB cables.
3. Enter the following command:

```
ibtsta
```

If `ibtsta` completes with no errors, you have installed the NI-488.2M software correctly.

Troubleshooting Software Problems

- Check for the correct Ethernet address in the file `/etc/ethers`.
- Check for the correct alias name, `gpib0`, in the file `/etc/hosts`.
- Verify that the `gpibrc` file was copied to the `/etc` directory.

Common Questions

My driver is not communicating with the GPIB-ENET. What should I do?

Check to see if the GPIB-ENET is configured properly. To isolate the problem, try to *ping* your GPIB-ENET to make sure it is recognizable on the network. *ping* is a network utility that sends a packet to a device/host on the network, then waits for it to be echoed back, which indicates an active device/host.

Use one of the following commands:

```
/etc/ping IPaddress  
/etc/ping alias
```

where *IPaddress* is the IP address assigned to your GPIB-ENET, and *alias* is the name assigned to your GPIB-ENET in the `/etc/hosts` file. If *ping* fails, the GPIB-ENET may not be properly configured or installed. Refer to Chapter 2, *Configuring and Installing the Hardware*, and Chapter 3, *Installing and Configuring the Software*, for detailed configuration instructions. Once you have verified that the GPIB-ENET is configured and installed properly, if you are still unable to communicate with the GPIB-ENET, contact National Instruments.

My I/O worked with a board interface, but it times out when I use the GPIB-ENET interface. What should I do?

Network communication is slower than straight cable communication. You might need to raise the default **Timeout** value using `ibconf`.

The Update utility reports a checksum error. What should I do?

Run the `Update` utility again. Your imagefile might be corrupted. If the same message appears when you run the utility again, try reinstalling your NI-488.2M software and then running the `Update` utility again.

I powered off my GPIB-ENET before recording the flashing READY LED pattern. What should I do?

Try to duplicate the error before calling National Instruments for assistance. Recording the **READY** LED pattern is not critical to the operation of your GPIB-ENET, but it saves you time and helps Product Support diagnose the problem quickly and accurately.

How many GPIB-ENET boxes can I configure for use with my NI-488.2M software?

The GPIB-ENET NI-488.2M software supports up to eight GPIB-ENET boxes by default. You can modify the software to support up to 128 GPIB-ENET boxes. See the *Increase the Allowed Number of Boxes or Devices (Optional)* section of Chapter 3, *Installing and Configuring the Software*, for information on increasing the allowed number of boxes.

How many devices can I configure for use with my GPIB-ENET and NI-488.2M software?

The GPIB-ENET NI-488.2M software supports up to 44 logical devices by default. You can modify the software to support up to 128 logical devices. See the *Increase the Allowed Number of Boxes or Devices (Optional)* section of Chapter 3, *Installing and Configuring the Software*, for information on increasing the allowed number of devices.

When should I use the `ibic` utility?

You can use the `ibic` utility to test and verify instrument communication, troubleshoot problems, and develop your application program. For more information, refer to the *NI-488.2M Software Reference Manual*.

How do I use an NI-488.2M language interface?

For information about using NI-488.2M language interfaces, refer to the *NI-488.2M Software Reference Manual*.

What information should I have before I contact National Instruments?

When you contact National Instruments, you should provide the results of `ibtesta`. Also, make sure you have filled out the configuration form in Appendix E, *Customer Communication*.

Chapter 5

Using Your NI-488.2M Software

This chapter describes the `ibic` utility and lists some programming considerations.

Introduction to the `ibic` Utility

You can use the interactive control utility to enter NI-488 functions and NI-488.2 routines interactively and display the results of the function calls automatically. Without writing an application, you can use the utility to do the following:

- Verify GPIB communication with your device quickly and easily.
- Learn the NI-488 functions and NI-488.2 routines before you write your application.
- Become familiar with the commands of your device.
- Receive data from your GPIB device.
- Troubleshoot problems with your application.

For more information about the `ibic` utility, refer to the *NI-488.2M Software Reference Manual*.

General Programming Considerations

As you begin developing your GPIB application, remember the following points:

- You must link the language interface library with your compiled source code. Include the `cib.o` object file during the link phase of each application compile operation or link the GPIB library `libgpib` as shown by the following examples:

```
cc test.c cib.o
```

or

```
cc test.c -lgpib
```

- You must include the header file `sys/ugpib.h` in your source code.

For information about choosing a programming method, developing your application, NI-488.2 functions, or compiling and linking, refer to the *NI-488.2M Software Reference Manual*.

The NI-488.2M functions are compatible with any other NI-488.2M functions used with other National Instruments products, except for the following functions:

- `ibdma`
- `IBGET`, `IBSET`, `IBDINFO`

For more information on the GPIB library, refer to the *Install the Software* section in Chapter 3, *Installing and Configuring the Software*.

Appendix A

Hardware Specifications

This appendix lists the electrical, environmental, and physical characteristics of the GPIB-ENET and the recommended operating conditions.

Table A-1. Electrical Characteristics

Characteristic	Specification
Power Supply Unit	100-120 VAC $\pm 10\%$, 50-60 Hz or 220-240 VAC $\pm 10\%$, 50-60 Hz
Maximum Current Requirement	100-120 VAC 110 mA or 220-240 VAC 55 mA
Fuse Rating and Type	100-120 VAC 300 mA, UL/CSA approved 220-240 VAC 500 mA, IEC approved

Table A-2. Environmental Characteristics

Characteristic	Specification
Operating Temperature	0° to 40° C
Storage Temperature	-20° to 70° C
Relative Humidity	10% to 90% noncondensing conditions
EMI	FCC Class A Verified

Table A-3. Physical Characteristics

Characteristic	Specification
Overall Case Size (Dimensions)	3.5 in by 5.65 in. by 1.62 in. (8.89 cm by 14.35 cm by 4.11 cm)
Case Material	All metal enclosure
Weight	0.9 lb (0.41 kg)

Appendix B

GPIB-ENET 8-Bit DIP Switch

This appendix describes how each of the DIP switches on the back panel affects the operation of the GPIB-ENET.

The 8-bit DIP switch is located on the back panel of the GPIB-ENET, as shown in Figure B-1. The DIP switches are used to set the operation mode of the GPIB-ENET. The GPIB-ENET is shipped to you with the DIP switches set for normal operation mode; all the switches are in the OFF position.

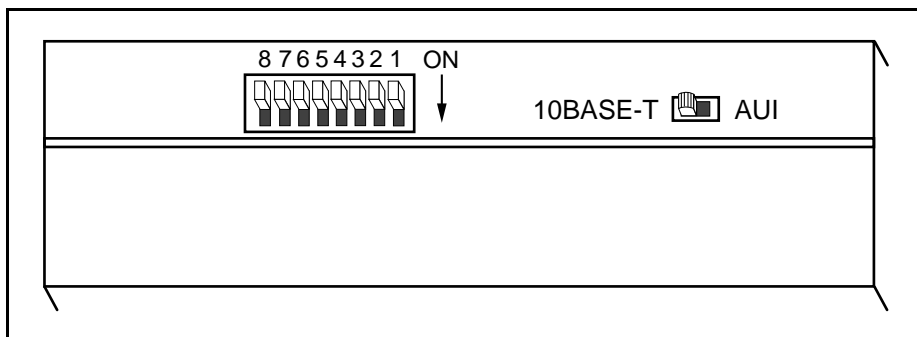

Figure B-1. GPIB-ENET Back Panel Switches

Table B-1 shows the possible configurations of the GPIB-ENET DIP switches and what each configuration indicates. The entries in ***bold italic*** text represent the default settings.

Table B-1. DIP Switch Settings for Modes of Operation

Switch	Position	Indication
8	ON	Extended Factory Test
	<i>OFF</i>	<i>Normal Operation</i>
7	ON	Modify Mode
	<i>OFF</i>	<i>Normal Operation</i>
6	ON	Use Stored IP Address
	<i>OFF</i>	<i>Obtain IP Address</i>
5	ON	Manual IP Assignment
	<i>OFF</i>	<i>Automatic IP Assignment</i>
4-1	<i>OFF</i>	<i>These switches are reserved and should remain OFF.</i>

Switch 8 selects the Extended Factory Test mode and should remain OFF for normal operating mode. When this switch is ON, the GPIB-ENET performs extended tests which require special connections to the GPIB and Ethernet ports. Without these connections, the GPIB-ENET cannot pass the extended factory tests.

Switch 7 selects the Modify Mode and should remain OFF for normal operating mode. The firmware controlling the GPIB-ENET is stored in an electrically erasable memory. When this switch is ON, you can reprogram the firmware memory from the Ethernet network using the `Update` utility, or you can modify the subnet information using the `IPsetup` utility. Refer to Appendix C, *GPIB-ENET Configuration Utilities*, for more information.

Switch 6 indicates how the GPIB-ENET IP address is determined when it is powered on. If switch 6 is OFF, the GPIB-ENET expects to receive its IP address from the network. If switch 6 is ON, the GPIB-ENET retrieves the IP address that is stored in nonvolatile memory.

Switch 5 selects the method by which IP addresses are configured in the GPIB-ENET. When switch 5 is OFF, the GPIB-ENET issues Reverse Address Resolution Protocol (RARP) requests each time it is powered on. The GPIB-ENET continues to issue RARP requests until a valid RARP reply is received. If switch 5 is ON, the GPIB-ENET does not issue RARP requests. In most networks, the GPIB-ENET can use RARP to have its address automatically configured; however, there are some networks which, for security or other reasons, do not use RARP. In this case, you must configure the IP address of the GPIB-ENET using `IPassign`. Refer to Appendix C, *GPIB-ENET Configuration Utilities*, for more information on `IPassign`. Regardless of the method by which an IP address is obtained, the GPIB-ENET stores the address in nonvolatile memory. Note that if switch 6 is ON, the setting of switch 5 is ignored.

Switches 1-4 are reserved for future expansion and should remain OFF.

Appendix C

GPIB-ENET Configuration Utilities

This appendix contains information on the `IPassign`, `Update`, and `IPsetup` utilities for the GPIB-ENET.

IPassign Utility

Use the `IPassign` utility to manually configure the IP address of your GPIB-ENET. Once you configure the IP address, it is stored in nonvolatile memory in the GPIB-ENET. You only need to run the `IPassign` utility when the box is new or when you decide to reconfigure your network in a way that changes the IP address of the GPIB-ENET.

The `IPassign` utility must be run on a machine that is connected to the same subnet as the GPIB-ENET you are configuring.

To run `IPassign`, follow these steps after you have connected the GPIB-ENET to the network and installed the NI-488.2M software.

1. Make sure you know the Ethernet address of the GPIB-ENET (listed on the bottom panel of the box) and the IP address of your GPIB-ENET (assigned by your network administrator). If you do not know the IP address, refer to the *Configure the Network* section of Chapter 3, *Installing and Configuring the Software*.
2. Power off the GPIB-ENET. Make sure that all of the DIP switches are OFF except for switch 5, which should be ON. This indicates that you want to use `IPassign` to configure the IP address.
3. Power on the GPIB-ENET and wait 10 seconds for the power-on self-tests to complete. The **READY** LED will continue to flash.
4. Run `IPassign`. This utility is always invoked with two parameters: an Ethernet address and an IP address. These addresses are entered in standard notation, which for the Ethernet address is six hexadecimal numbers separated by colons. Standard notation for the IP address is four decimal numbers separated by periods. For example, the following numbers program the IP address 130.164.1.1 into the GPIB-ENET located at Ethernet address 00:80:2F:FF:00:10.

```
IPassign 00:80:2F:FF:00:10 130.164.1.1
```

5. The utility constructs 10 packets and sends them across the local Ethernet. When the GPIB-ENET successfully receives its IP address, the **READY** LED remains steady. As long as the **READY** LED is not steady, the address has not been configured.

Because the packets do not form a guaranteed delivery protocol, it is possible (though extremely unlikely) for all 10 packets to get lost in the network and for

the GPIB-ENET not to receive any of them. In this case, repeat Step 4 several times until the GPIB-ENET successfully receives its new IP address, indicated by a steady **READY LED**. If after several attempts, the **READY LED** does not become steady, contact National Instruments for further assistance.

6. When the **READY LED** remains steady, power off the GPIB-ENET. Set DIP switch 5 to the OFF position and switch 6 to the ON position. With the switches in this position, the GPIB-ENET powers on with the IP address stored in nonvolatile memory. For more information on the DIP switch settings, refer to Appendix B, *GPIB-ENET 8-Bit DIP Switch*.
8. Power on the GPIB-ENET and wait for the **READY LED** to come on and remain steady. If the **READY LED** does not become steady, the slow blinking indicates an internal GPIB-ENET error. Refer to Appendix D, *READY LED Signaling*, to determine which error is being reported.

Update Utility

If you have received your NI-488.2M software as an update to your current GPIB-ENET, you need to update the firmware in the GPIB-ENET. Electrically Erasable Programmable Read Only Memory (EEPROM) stores the firmware that controls the GPIB-ENET. You can use the `Update` utility to upgrade the firmware in the EEPROM. The latest firmware file is called `GPIBENET.bin`.

Caution: *Because of the potential loss of EEPROM functionality, it is extremely important to follow the instructions in this section. Please read this entire section before attempting to update your firmware.*

If you are directly linked to the Internet, and not just to an isolated network using IP protocols, you can contact the National Instruments GPIB Product Support Department to update your firmware. If you are not on the actual Internet or you want to update the firmware yourself, you can execute `Update` locally. In either case, pay close attention to the GPIB-ENET **READY LED**, which reports important status codes.

Although you should update your firmware as needed, the number of times you can do so is limited. Therefore, update the firmware only when necessary. Also, notice that there is a time period of about two seconds when the GPIB-ENET runs exclusively in volatile RAM memory with the EEPROMs erased. If the box loses power during this time, it is no longer usable and must be returned to National Instruments for repair. If you are not comfortable with this procedure, call National Instruments for assistance.

Caution: *Because of the potential loss of EEPROM information, do not attempt to update the firmware when your electrical power is in danger; that is, during a weather storm or similar situation. Once you have started the update process, do not switch off power to your GPIB-ENET until you see and record the flashing **READY LED** pattern.*

The following steps describe how to update the firmware.

1. Power off the GPIB-ENET and set DIP switch 7 of the DIP switch to the ON position.
2. Power on the GPIB-ENET and wait for the **READY** LED light to remain steady.
3. Run `Update`. This utility is always invoked with two parameters: an imagefile name and a host name. For example, the following command copies the imagefile `GPIBENET.bin` into the EEPROMs of `gpib0.natinst.com`.

```
update GPIBENET.bin gpib0.natinst.com
```

4. Wait for the **READY** LED to begin flashing, which signals that the update is complete. Do *not* power off your GPIB-ENET before you see and record the flashing **READY** LED pattern.

If the programming is successful, the **READY** LED signals a status code of 00, signified by one long flash and one short flash. Other patterns are used to indicate that the EEPROMs did not program properly. If a pattern other than 00 is indicated, refer to Appendix D, *READY LED Signaling*, for more information on recording the flashing pattern.

5. Power off the GPIB-ENET and return DIP switch 7 to the OFF position.
6. Power on the GPIB-ENET and wait for the **READY** LED to remain steady. If the **READY** LED does not remain steady, repeat the update procedure.

IPsetup Utility

Use the `IPsetup` utility to configure the IP characteristics of the specified GPIB-ENET. The IP characteristics include the following:

- Broadcast IP address—used by an IP device when a packet must go to all devices on the local subnet.
- Netmask of the local subnet—used by an IP device to determine if the destination of an out-going packet is local (that is, on the same subnet). If the destination is local, no routing is required. If the destination is not local, routing is required.
- List of router IP addresses—used when an IP device determines that the destination of a packet is not on the local subnet. If routing is required, the best route is chosen dynamically. Up to four default routers can be specified.

Note: *You should not run this utility without assistance from your network administrator.*

The following steps describe how to configure the IP characteristics:

1. Power off the GPIB-ENET, and set DIP switch 7 to the ON position.
2. Power on the GPIB-ENET and wait for the **READY** LED light to remain steady.
3. Run `IPsetup`. This utility takes no command line parameters. All necessary information is obtained during execution.
4. Enter the appropriate information as it is requested. For additional information about each piece of information requested, enter a single question mark (?).
5. Power off the GPIB-ENET, and return DIP switch 7 to the OFF position.
6. Power on the GPIB-ENET and wait for the **READY** LED to remain steady.

Appendix D

READY LED Signaling

This appendix describes how to interpret the **READY** LED error codes.

READY LED Overview

The **READY** LED has several purposes on the GPIB-ENET. When you first power on the GPIB-ENET, the **READY** LED flashes quickly while it completes its power-on self-tests. When the tests complete successfully and the IP address is assigned from either nonvolatile memory or the network, the **READY** LED remains steady, indicating that the unit is ready to operate.

During operation, the **READY** LED might begin to blink slowly. This occurs after running the `Update` utility, when the GPIB-ENET reports status on the operation. Refer to Appendix C, *GPIB-ENET Configuration Utilities*, for more information. At other times, the **READY** LED blinks slowly to alert you of internal GPIB-ENET errors. For assistance in correcting this problem, use this appendix to interpret and record the pattern that the **READY** LED flashes, and then contact National Instruments.

Note: *By recording the **READY LED** status messages before calling National Instruments, you can save yourself time, and the GPIB Product Support Department can answer your questions more accurately and efficiently. Do not switch off power to your GPIB-ENET before recording the flashing **READY LED** pattern.*

READY LED signaling can report up to 100 different errors. The errors are numbered from 0 to 99 and are reported through sequences of **READY** LED flashes.

Step 1. Count the Long Flashes

A three-second interval, during which the **READY** LED is OFF, separates each repetition of the sequence. The sequence begins with a series of long one-second flashes—that is, one second ON, one second OFF. These long flashes represent the digit in the tens column. There can be 1 to 10 long flashes, which represent digits 0 through 9. For example, one long flash represents the digit 0 in the tens column, two long flashes represent the digit 1 in the tens column, and 10 long flashes represent the digit 9 in the tens column.

Step 2. Count the Short Flashes

The long flashes are followed by shorter flashes; each short flash lasts about one-fifth of a second. These short flashes represent the digit in the ones column. Again, there can be 1 to 10 flashes, which represent the digits 0 through 9. For example, one short flash represents the digit 0 in the ones column, two short flashes represent the digit 1 in the ones column, and 10 short flashes represent a 9 in the ones column.

Using this method, the **READY** LED flashes the following sequence to represent status message 11.

[three seconds OFF] [two long flashes] [two short flashes] [three seconds OFF]. . .

The **READY** LED flashes the following sequence to represent status message 30.

[three seconds OFF] [four long flashes] [one short flash] [three seconds OFF]. . .

Step 3. Record Your Status Code Number

When you have computed your status code number, record it on the *GPIB-ENET Hardware and Software Configuration Form* in Appendix E, *Customer Communication*, before calling National Instruments.

Table D-1 lists some examples of the long and short flashes and the status codes they report.

Table D-1. Sample **READY** LED Signals and the Corresponding Status Code Numbers

Number of Long Flashes	Number of Short Flashes	Corresponding Status Code Number
1	1	00
2	1	10
5	3	42
1	8	07
3	4	23
10	10	99

Appendix E

Customer Communication

For your convenience, this appendix contains forms to help you gather the information necessary to help us solve technical problems you might have as well as a form you can use to comment on the product documentation. Filling out a copy of the *Technical Support Form* before contacting National Instruments helps us help you better and faster.

National Instruments provides comprehensive technical assistance around the world. In the U.S. and Canada, applications engineers are available Monday through Friday from 8:00 a.m. to 6:00 p.m. (central time). In other countries, contact the nearest branch office. You may fax questions to us at any time.

Corporate Headquarters

(512) 795-8248

Technical support fax: (800) 328-2203
(512) 794-5678

Branch Offices	Phone Number	Fax Number
Australia	03 9 879 9422	03 9 879 9179
Austria	0662 45 79 90 0	0662 45 79 90 19
Belgium	02 757 00 20	02 757 03 11
Canada (Ontario)	519 622 9310	519 622 9311
Canada (Quebec)	514 694 8521	514 694 4399
Denmark	45 76 26 00	45 76 71 11
Finland	90 527 2321	90 502 2930
France	1 48 14 24 24	1 48 14 24 14
Germany	089 741 31 30	089 714 60 35
Hong Kong	2645 3186	2686 8505
Italy	02 48301892	02 48301915
Japan	03 5472 2970	03 5472 2977
Korea	02 596 7456	02 596 7455
Mexico	95 800 010 0793	5 520 3282
Netherlands	0348 433466	0348 430673
Norway	32 84 84 00	32 84 86 00
Singapore	2265886	2265887
Spain	91 640 0085	91 640 0533
Sweden	08 730 49 70	08 730 43 70
Switzerland	056 200 51 51	056 200 51 55
Taiwan	02 377 1200	02 737 4644
U.K.	01635 523545	01635 523154

Technical Support Form

Photocopy this form and update it each time you make changes to your software or hardware, and use the completed copy of this form as a reference for your current configuration. Completing this form accurately before contacting National Instruments for technical support helps our applications engineers answer your questions more efficiently.

If you are using any National Instruments hardware or software products related to this problem, include the configuration forms from their user manuals. Include additional pages if necessary.

Name _____

Company _____

Address _____

Fax (____) _____ Phone (____) _____

Computer brand _____

Model _____ Processor _____

Operating system _____

Speed _____MHz RAM _____MB

Display adapter _____

Mouse _____yes _____no

Other adapters installed _____

Hard disk capacity _____MB Brand _____

Instruments used _____

National Instruments hardware product model _____

Revision _____

Configuration _____

National Instruments software product _____

Version _____

Configuration _____

(continues)

The problem is _____

List any error messages _____

The following steps will reproduce the problem _____

GPIB-ENET Hardware and Software Configuration Form

Record the settings and revisions of your hardware and software on the line to the right of each item. Update this form each time you revise your software or hardware configuration, and use this form as a reference for your current configuration.

National Instruments Products

- GPIB-ENET Model and Hardware Revision _____
- 10Base-T or Coax version _____
- Input voltage (100-120 or 220-240) _____
- NI-488.2M Software Version Number on Distribution Medium _____
- DIP Switch Setting _____
- IP Address _____
- Ethernet Port Configuration Slide Switch Setting _____
- **READY** LED Signaling Status Code _____

Other Products

- Computer Model _____
- Application Programming Language _____
- SunOS Version _____
- Other Ethernet devices in System _____
- Other GPIB devices in System _____

Documentation Comment Form

National Instruments encourages you to comment on the documentation supplied with our products. This information helps us provide quality products to meet your needs.

Title: **Getting Started with Your GPIB-ENET and the NI-488.2M™
Software for the Sun SPARCstation**

Edition Date: **October 1995**

Part Number: **320528B-01**

Please comment on the completeness, clarity, and organization of the manual.

(continues)

Glossary

Prefix	Meaning	Value
m-	milli-	10^{-3}
c-	centi-	10^{-2}
k-	kilo-	10^3
M-	mega-	10^6

°	degrees
%	percent
A	amperes
AC	alternating current
ANSI	American National Standards Institute
AUI	Attachment Unit Interface
C	Celsius
DIP	dual inline package
EEPROM	Electrically Erasable Programmable Read Only Memory
EMI	electromagnetic interference
FCC	Federal Communications Commission
g	grams
GPIO	General Purpose Interface Bus
Hz	hertz
IEEE	Institute of Electrical and Electronic Engineers
in.	inches
IP	Internet Protocol
lb	pounds
LED	light-emitting diode
m	meters
MB	megabytes of memory
RAM	random-access memory
RARP	Reverse Address Resolution Protocol
sec	seconds
TCP	Transmission Control Protocol
V	volts
VAC	volts alternating current